

# UCK42V9000

## 1 Summary

### Characteristics

- CE、UL、RoHS certified
- Up to 65Wh/kg energy density
- Working temperature window :-25 ~ 55°C
- Up to 50,000 cycles under 5C rate current (2.8 ~ 4.05V)
- Up to 2160kWh/kg discharged specific energy over whole life span (2.8 ~ 4.05V)
- Higher power density than battery
- Accurate CMS regulation and control with good linear charge and discharge behavior

### Applications

- City bus
- Tunnel locomotive
- Mining locomotive
- Port truck
- Marine power supply
- Energy-saving elevator
- Emergency UPS
- Smart power grids
- Energy storage of renewable energy sources such as wind and solar power
- Other high power and high energy applications

## 2 Dimension

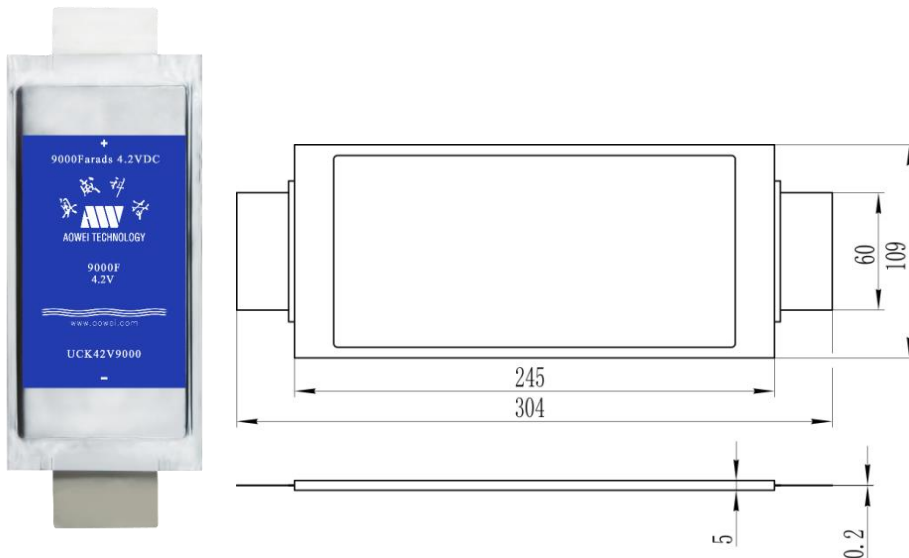

### 3 Product Specification

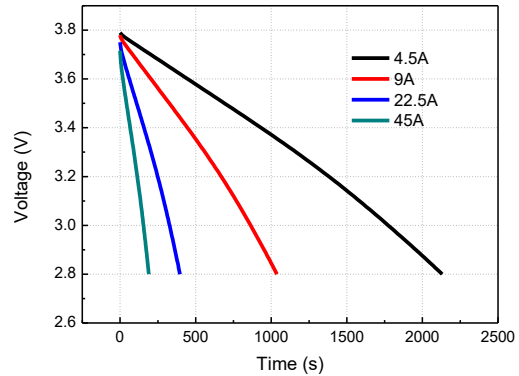
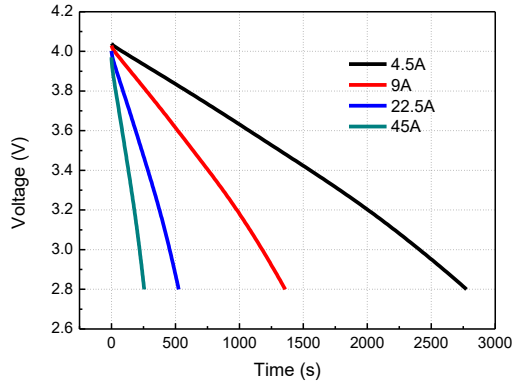

Discharge curves under 2.8 ~ 4.05V (left) and 2.8 ~ 3.8V (right) of UCK42V9000

Part Number	UCK42V9000
Operating Voltage Window (V)	2.8 ~ 4.05
	2.8 ~ 3.8
Nominal Capacitance (F)	9000
DC Resistance (mΩ)	1.2
Stored Energy (Wh)	15 (2.5 ~ 4.2V) <sup>§</sup>
	11 (2.8 ~ 4.05V)
	7 (2.8 ~ 3.8V)
Energy Density (Wh/kg)	65 (2.5 ~ 4.2V) <sup>§</sup>
	48 (2.8 ~ 4.05V)
	30 (2.8 ~ 3.8V)
Standard Charge/Discharge Current (A)	25
Maximum Charge/Discharge Current(<20s) (A)	90
Cycle Life (cycles)	50000 (2.8 ~ 4.05V)
	1,000,000 (2.8 ~ 3.8V)
Weight (g)	230
Dimensions (L×W×H) (mm)	304×109×5
Operating Temperature (°C)	-25 ~ +55
Storage Temperature (°C)	-30 ~ +60
§Remark: Stored Energy and energy density are tested according to article 6.2.5 in QC/T 741-2014 Ultra-capacitor for electric vehicles	

## 4 Test method

### Test conditions

- Ambient temperature:  
25±5°C
- Relative humidity:  
25% ~ 85%
- Ambient pressure:  
86 ~ 106kPa

### Standards and conformity

- IEC 62576-2009 Electric double-layer capacitors for use in hybrid electric vehicles-Test methods for electrical characteristics
- QC/T 741-2014 Ultra-capacitor for electric vehicles
- Q/TFDQ 11-2012 UCK Series Ultra capacitor

## 5 Announcements

### Operating requirements

- Operating exceeding the upper or lower operating temperature limit is strictly prohibited.
- Operating exceeding the maximum or minimum operating voltage is strictly prohibited.
- Short-circuit and reverse connection of the unit is strictly prohibited.
- Crush, collision, penetration or disassembly of the capacitor is strictly prohibited.
- Operating after cell swollen is strictly prohibited.
- Abandoning used capacitor is strictly prohibited, please discharge capacitor to 0V before recycling
- Please keep away from all heat sources
- Please avoid contacting water, oil, acid, alkali and other corrosive matters
- Juveniles should operate the unit accompanied by parents

### Storage and transportation requirements

- Ambient temperature: -30 ~ 60°C
- Relative humidity: 0~95%
- Ambient pressure: 86 ~ 106kPa
- Storage or transportation of cell voltage below 2.5V is strictly prohibited. Please recharge the unit before long time storage, and recharge interval should be no longer than 6 months
- Please keep the unit protected, and prevent from short circuit
- Prevent exposing in the sun, keep away from heat sources and keep dry and ventilated
- Avoid contact of liquid or corrosive matters
- Please handle gently during handling process, prevent inversion, collision, crush or vibration during the process of transportation
- The unit can be transported by cars, trains, ships, etc

## 6 Product liability

- Aowei shall not be held responsible for the accident which caused by the violation of this specification
- Improvements of the product or upgrading of related technologies may change without further notice
- Please deal with the used ultra capacitor according to local environmental protection regulations. The used capacitor shall be treated as general industrial waste. Considering the recycling classification and resource reutilization of trashed or used chemical power units, used capacitor should be submitted to the company with professional qualifications. For the matters of disposal and recycle, GB/T 33598-2017 Recycling of traction battery used in electric vehicle-Dismantling specification can be the reference. Aowei could provide part of technical support depending on mutual agreements
- To learn about the new products, welcome to contact us.